

DATE
2/13/91

No.	REVISIONS
1	TEMPLATE REDRAWN

- NOTES
1. DO NOT SCALE DRAWING.
 2. DIMENSIONS ARE IN INCHES/(MM).
 3. ALL NECESSARY REINFORCING FOR PIVOTS BY OTHERS.
 4. PIVOT PIN DIAMETER .591/(15MM).
 5. PIVOT PIN PROJECTION IS ADJUSTABLE.
- SEE CHART FOR DOOR CLEARANCES.

DOOR CLEARANCE		
POSITION	STANDARD PIN	EXTENDED PIN
A	1/8" (3)	3/4" (19)
B	3/8" (10)	1" (25)
C	3/4" (19)	1-5/16" (33)

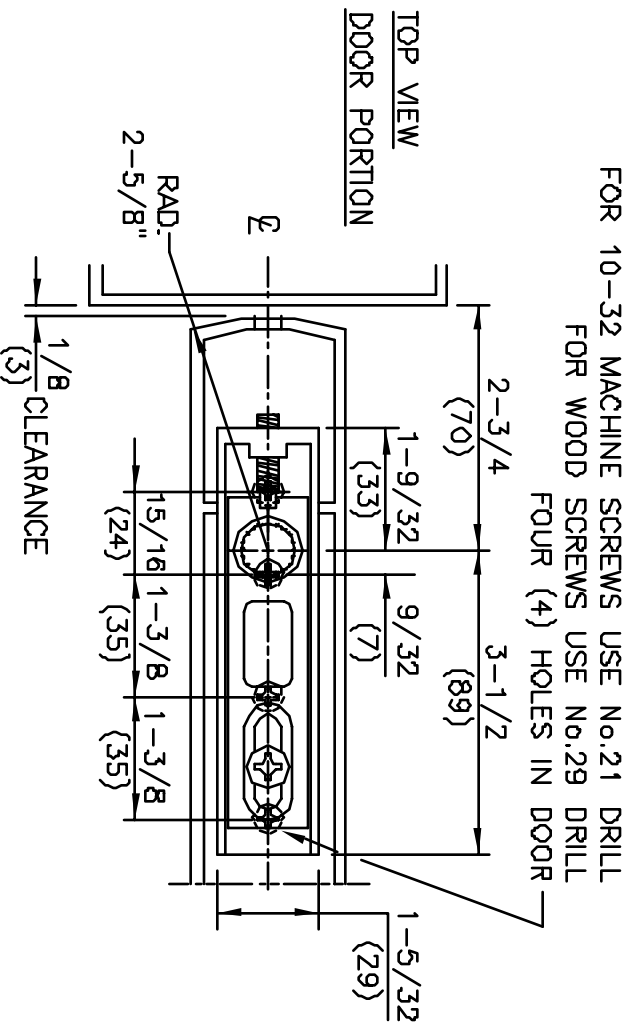
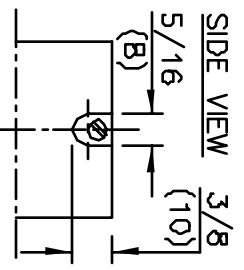
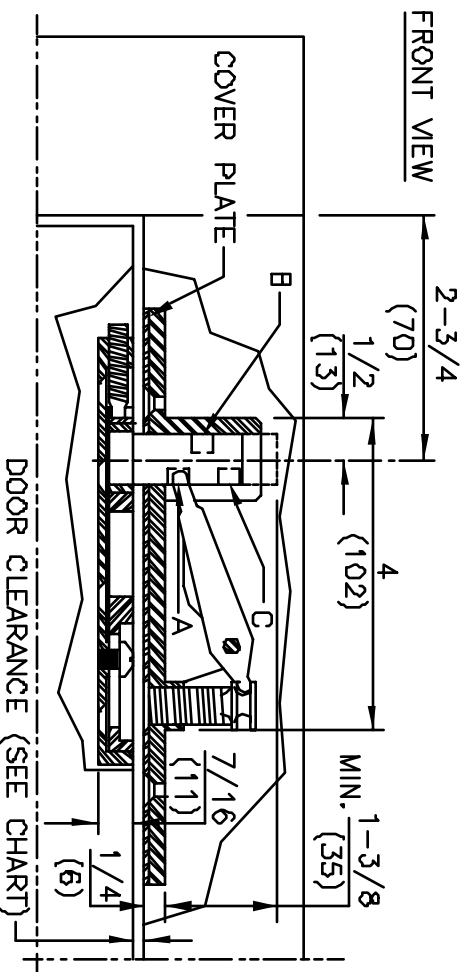
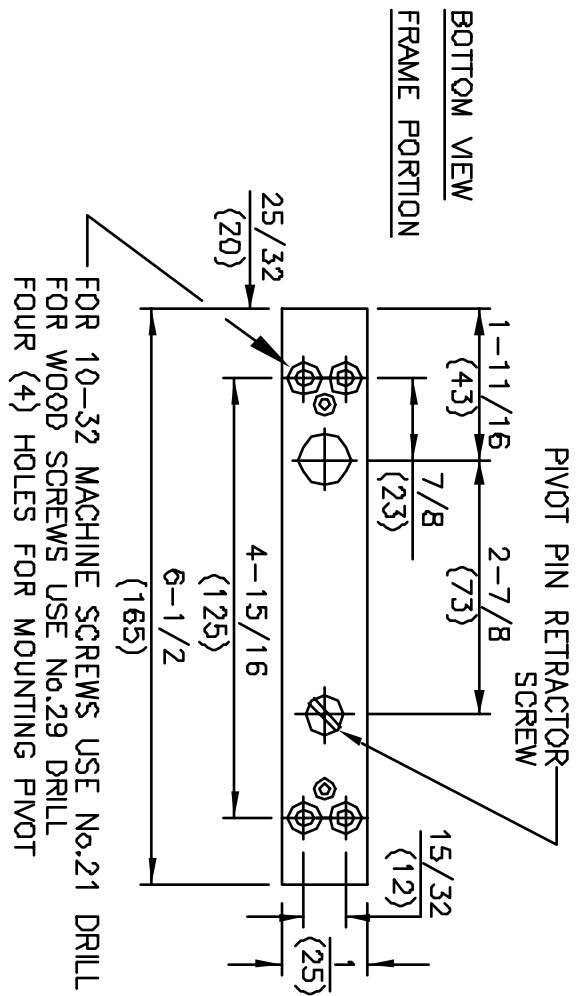

MODEL No. 8062, 8062 EXT PIN
CENTER HUNG TOP PIVOT



DORMA Architectural Hardware
REAVISTOWN, PENNSYLVANIA 17567
TEMPLATE No. LM-45

NOTES

1. DO NOT SCALE DRAWING.
2. DIMENSIONS ARE IN INCHES/(MM).
3. ALL NECESSARY REINFORCEMENT FOR ARM BY OTHERS.

No.	REVISIONS	DATE
1	REMOVED 7.5MM SPINDLE	10/6/03

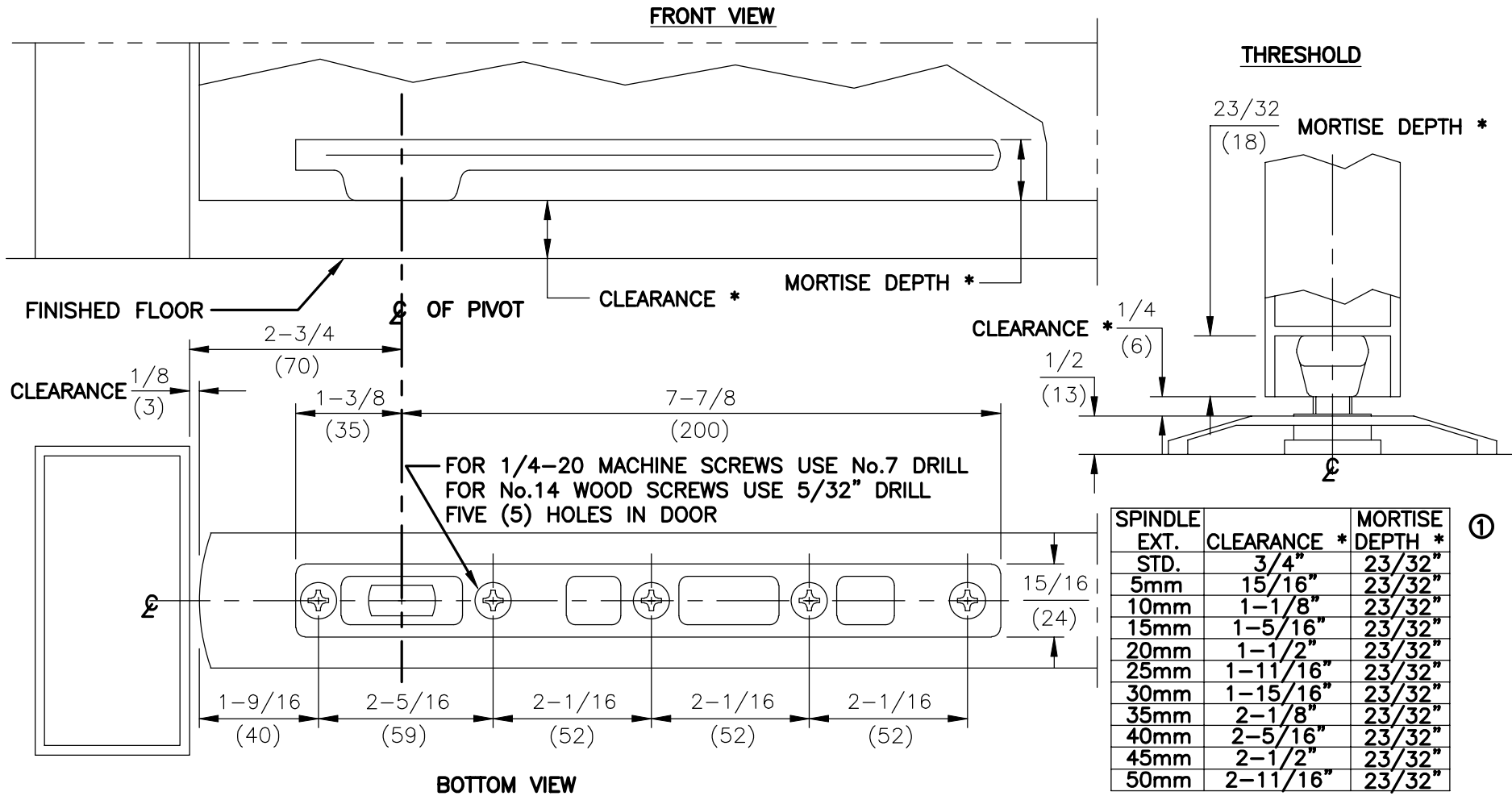

ITEM No. 7421
 CENTER HUNG BOTTOM ARM
 FOR USE WITH 7471K FLOOR BEARING



DORMA Architectural Hardware
 REAMSTOWN, PENNSYLVANIA 17567
 TEMPLATE No. LM-43

No.	REVISIONS	DATE
1	REDRAWN ON C.A.D. – SEE TCN# T-94	3/5/93
2	REVISED FROM 5/16" DRILL TO 1/4" DRILL 1" DEEP	8/2/04

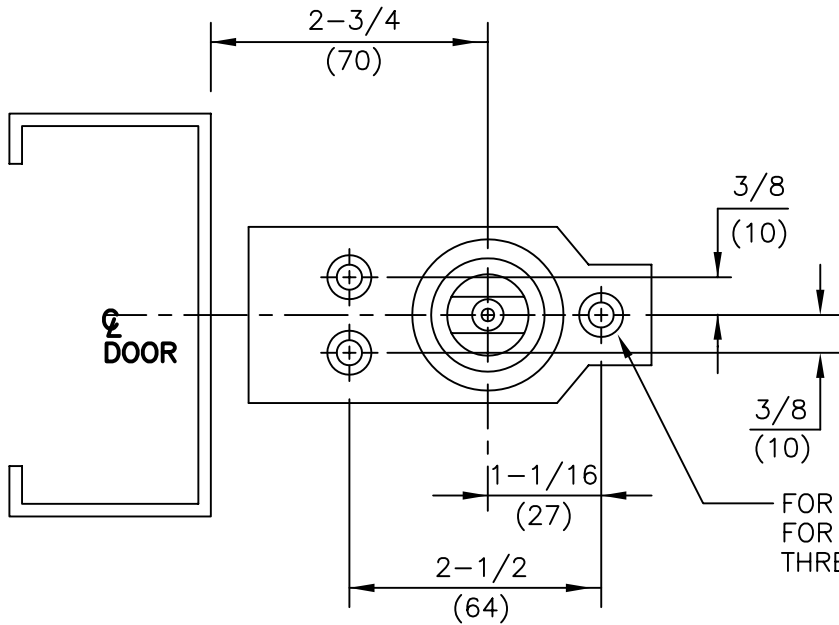

NOTES:

1. DO NOT SCALE DRAWING.
2. DIMENSIONS ARE IN INCHES\MM.
3. DIMENSION "A" IS DISTANCE FROM BOTTOM OF PIVOT TO BOTTOM OF ARM. WHEN BOTTOM ARM IS INSTALLED TO THE STANDARD TEMPLATE, THIS IS ALSO EQUAL TO THE BOTTOM DOOR CLEARANCE.

FOR WOOD FLOORS USE 1/8" DRILL
 FOR CONCRETE FLOORS USE 1/4" DRILL 1" DEEP
 THREE (3) HOLES

②

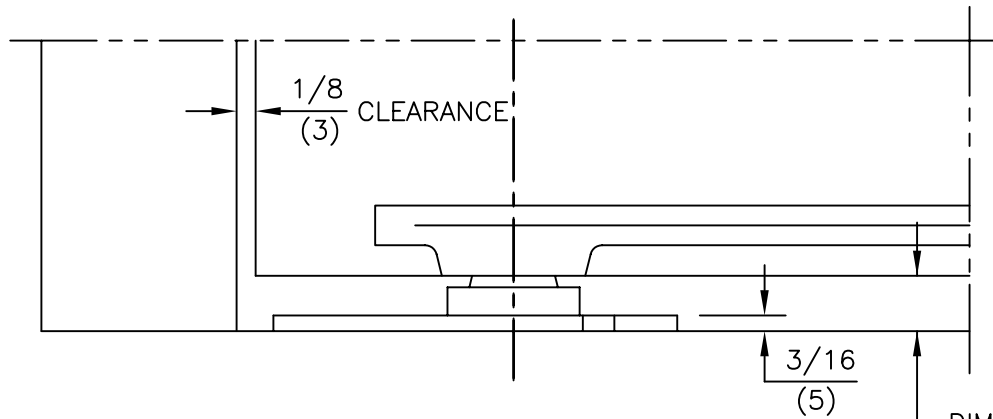

DIM. "A"
 SEE NOTE #3

SPINDLE SIZE	DIM. "A"
STD.	11/16 (17)
5mm	7/8 (22)
10mm	1-1/16 (27)
15mm	1-1/4 (32)
20mm	1-7/16 (37)
25mm	1-5/8 (42)
30mm	1-7/8 (47)
35mm	2-1/16 (52)
40mm	2-1/4 (57)
45mm	2-7/16 (62)
50mm	2-5/8 (67)

ITEM No.7471K
 CENTER HUNG FLOOR BEARING INSTALLATION
 FOR USE WITH 7421, 7422 BOTTOM ARMS



DORMA Architectural Hardware
 REAMSTOWN, PENNSYLVANIA 17567
 TEMPLATE No. LM-29 ②